

**CLIMA
HOSTELERIA**



- Code: EMP.6FG010

Thermostatic controller
Stainless steel baskets
Moving heaters provide easy cleaning
Front oil drainage valve
Safety thermostat for overheating protection.

Easy to clean and hygienic

Stainless steel body

Fryer chamber is monoblock pressed and rounded corners.

Chamber capacity 10 liter

Available a safety thermostat to prevent the oil from overheating.

Available one large basket in each chamber as standard.

Main information

Total power	7 kW
Gas consumption NG	0.74 m ³ /h
Gas consumption LPG	0.49 kg/h

Main information

Lenght	400 mm
Depth	664 mm
Height	285 mm
Net weight	25 kg
Product Net m ³ :	0.11
Packed Lenght	480 mm
Packed depth	870 mm
Packed height	600 mm
Packed weight	34,5 kg
Capacity	10 liter

Front

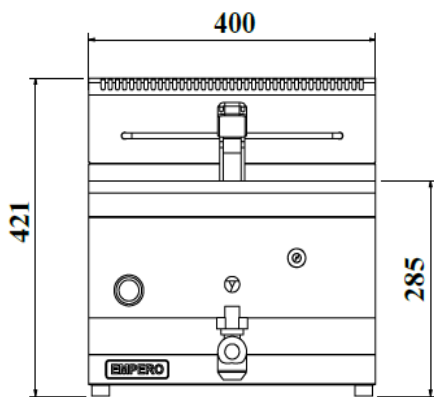

Side

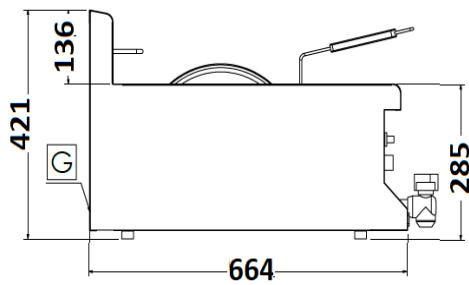

Back

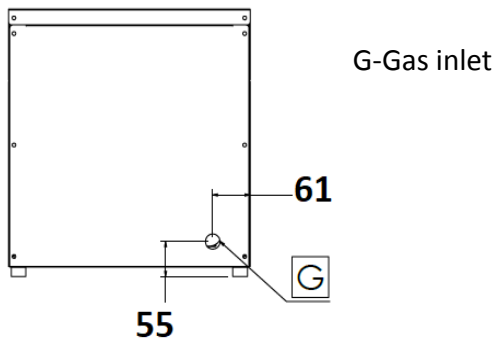

If this device is placed near the other devices that have heat sensitiveness or furniture. It has to be leaved distance minimum 150 mm or must be provided by isolation